

CKE900

Max. Lifting Capacity: 90 t
Max. Boom Length: 61.0 m
Max. Fixed Jib Combination: 57.9 + 18.3 m

S P E C I F I C A T I O N S

Main Boom	
Max. Lifting Capacity	90 t / 3.0 m
Max. Length	61.0 m
Fixed Jib	
Max. Lifting Capacity	10.8 t
Max. Length	18.3 m
Max. Combination	57.9 m + 18.3 m
Main & Aux. Winch	
Max. Line Speed	120 m/min (1st layer)
Rated Line Pull	111.8 kN (11.4 tf)
Max. Line Pull (Approx.)	196 kN (20 tf)
Wire Rope	25 mm
Wire Rope Length	235 m (Main) 160 m (Aux.)
Brake Type	Wet-type multi-disc brake
Free-Fall	Option
Working Speed	
Swing Speed	4.0 min ⁻¹ (rpm)
Travel Speed	1.9/1.2 km/h

Power Plant	
Model	Mitsubishi 6D24-TLU2D
Engine Output	235 kW/2,000 min ⁻¹ (rpm)
Fuel Tank Capacity	400 liters
Hydraulic System	
Main Pumps	3 variable displacement
Max. Pressure	31.9 MPa (325 kgf/cm ²)
Hydraulic Tank Capacity	450 liters
Self-Erection Device	Standard counterweight removal
Weight	
Operating Weight	Approx. 80.6 t
Counterweight	28.8 t (upper), 6.7 t (lower)
Transport Weight	44.7 t (Main machine with crawler and lower boom)
Ground Pressure	85 kPa (0.87 kgf/cm ²)

GENERAL DIMENSIONS

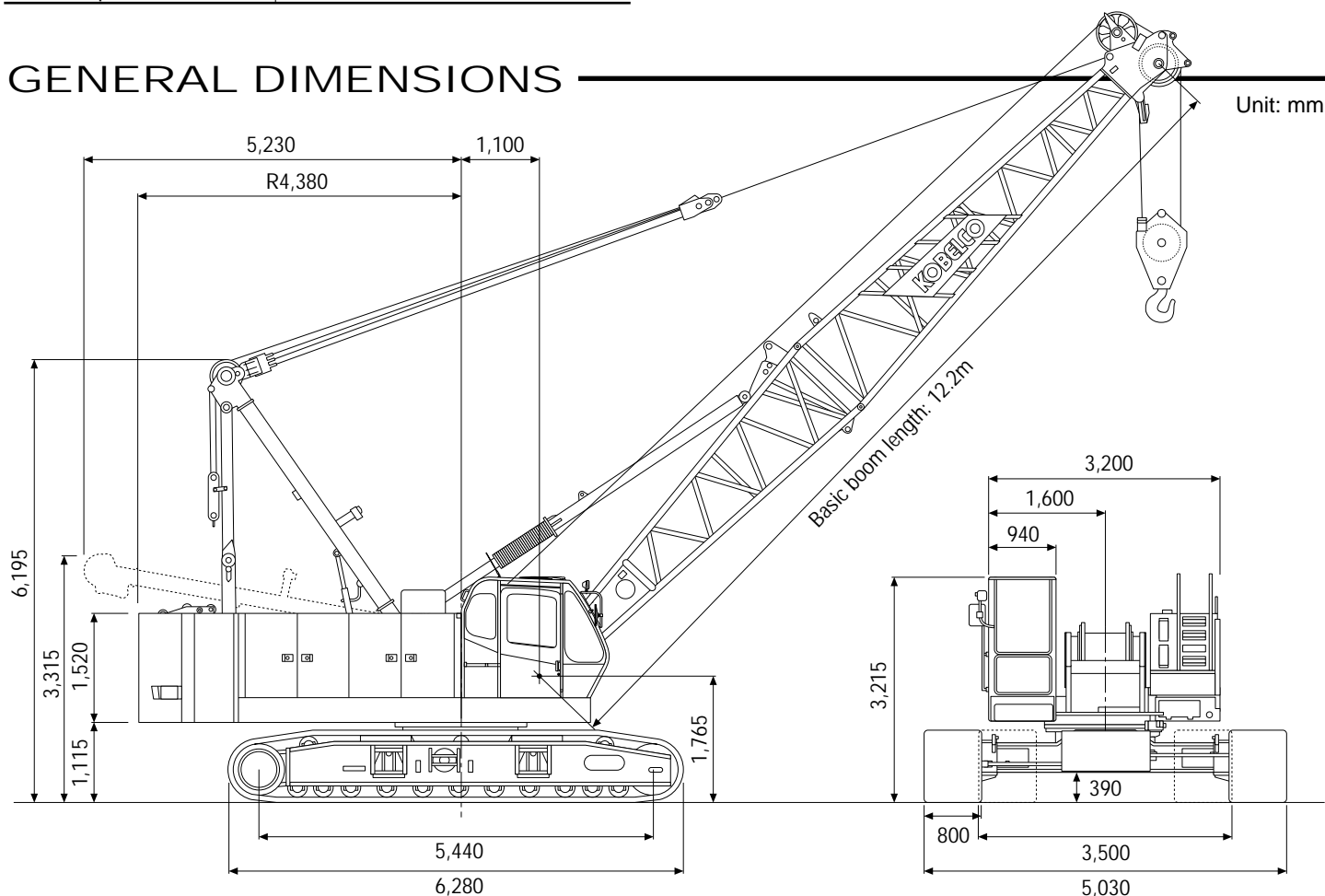

MAIN BOOM LIFTING CAPACITY

Rated loads in metric tons for 360° working area (Counterweight: 28.8 t, Carbody weight: 6.7 t)

Crawlers fully extended

Boom length m (ft)	12.2 (40)	15.2 (50)	18.3 (60)	21.3 (70)	24.4 (80)	27.4 (90)	30.5 (100)	33.5 (110)	36.6 (120)	39.6 (130)	42.7 (140)	45.7 (150)	48.8 (160)	51.8 (170)	54.9 (180)	57.9 (190)	61.0 (200)	
Working radius (m)	3.0	3.0/90.0	3.4/90.0	3.9/72.4														
	4.0	78.0	77.8	72.4	4.3/72.4	4.7/60.9												
	5.0	63.2	63.0	62.8	62.1	59.0	5.1/49.2	5.6/47.9										
	6.0	53.0	52.8	52.7	50.3	48.2	46.3	44.4	6.0/42.6	6.4/37.3	6.8/34.8							
	7.0	45.6	45.4	44.0	42.2	40.6	39.2	37.8	36.5	35.3	34.1	7.3/31.7	7.7/29.1					
	8.0	38.1	38.3	37.7	36.3	35.1	34.0	32.8	31.8	30.8	29.8	28.9	28.0	8.1/23.4	8.5/18.5			
	9.0	32.1	32.5	32.4	31.8	30.8	29.9	28.9	28.1	27.3	26.5	25.7	25.0	22.3	18.1	9.0/14.0	9.4/9.4	9.8/6.4
	10.0	27.1	28.1	28.0	27.9	27.4	26.7	25.8	25.1	24.5	23.8	23.1	22.5	21.2	17.1	13.2	9.0	6.3
	12.0	11.8/19.6	22.1	22.0	21.8	21.7	21.7	21.2	20.7	20.2	19.6	19.1	18.6	18.2	15.4	11.8	7.9	5.5
	14.0		17.1	18.0	17.9	17.7	17.7	17.5	17.4	17.1	16.6	16.1	15.8	15.4	14.0	10.6	7.0	4.7
	16.0		14.4/16.1	15.2	15.0	14.9	14.8	14.7	14.6	14.5	14.3	13.9	13.6	13.3	12.9	9.6	6.3	4.1
	18.0			17.0/13.4	12.9	12.8	12.7	12.5	12.5	12.4	12.2	12.1	11.9	11.6	11.3	8.8	5.6	3.5
	20.0				19.6/11.3	11.2	11.1	10.9	10.8	10.7	10.6	10.4	10.4	10.3	10.0	8.0	5.0	3.0
	22.0					9.9	9.8	9.6	9.5	9.4	9.3	9.1	9.0	9.0	8.9	7.3	4.5	2.6
	24.0					22.3/9.7	8.7	8.5	8.4	8.3	8.2	8.1	8.0	7.9	7.8	6.7	4.0	2.2
	26.0						24.9/8.3	7.6	7.6	7.5	7.3	7.2	7.1	7.0	6.9	6.2	3.5	1.8
	28.0							27.6/7.1	6.8	6.7	6.6	6.4	6.3	6.3	6.1	5.7	3.1	1.5
	30.0								6.2	6.1	5.9	5.8	5.7	5.6	5.5	5.2	2.8	30.0/1.2
	32.0								30.2/6.1	5.5	5.4	5.2	5.1	5.1	4.9	4.8	2.4	
	34.0									32.9/5.3	4.9	4.7	4.7	4.6	4.4	4.3	2.1	
36.0										35.5/4.6	4.3	4.2	4.1	4.0	3.9	1.8		
38.0											4.0	3.9	3.8	3.6	3.5	1.5		
40.0											38.1/3.9	3.5	3.4	3.3	3.1	1.3		
42.0												40.8/3.4	3.1	3.0	2.8	42.0/1.0		
44.0													43.4/2.9	2.7	2.6			
46.0														2.4	2.3			
48.0														46.1/2.4	2.0			
50.0															48.7/1.9			

- Note: 1. Rating according to DIN 15018/3 and prEN 13000.
- 2. Rating shown in are determined by the strength of the boom or other structural components.
- 3. Instruction in the operator's manual must be strictly observed when operating the machine.

WORKING RADIUS

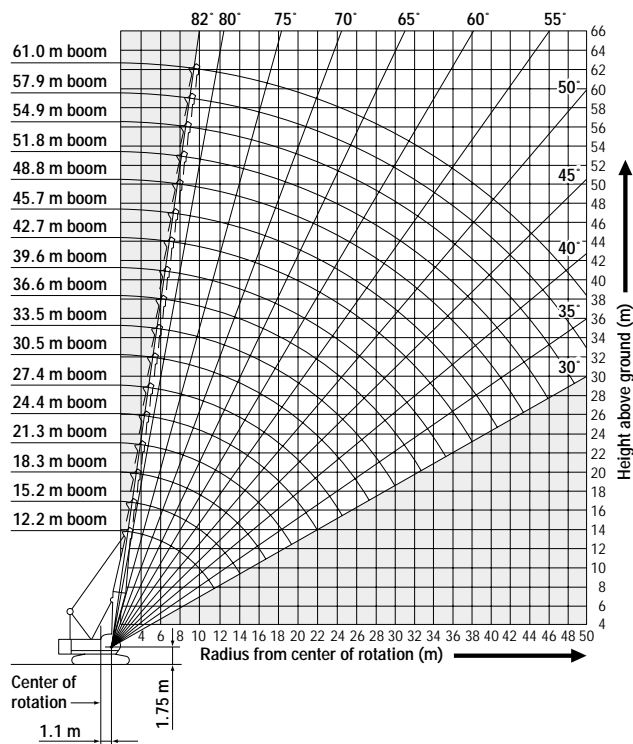

FIXED JIB LIFTING CAPACITY

PRELIMINARY

Rated loads in metric tons for 360° working area (Jib offset angle: 10°)

Boom length	24.4 m		42.7 m		57.9 m	
Jib length	9.1 m	18.3 m	9.1 m	18.3 m	9.1 m	18.3 m
10.0 m	10.4					
12.0 m	10.4					
14.0 m	10.4	7.8	10.4			
16.0 m	10.4	7.4	10.4		8.4	
18.0 m	10.4	6.6	10.4	7.8	8.1	
20.0 m	9.9	5.9	9.2	7.7	7.9	7.8
22.0 m	8.7	5.4	8.0	7.0	7.5	7.6
24.0 m	7.7	4.9	7.1	6.5	6.6	6.9
26.0 m	6.9	4.5	6.3	6.0	5.9	6.1
28.0 m	6.3	4.2	5.6	5.6	5.1	5.4
30.0 m	5.7	3.9	5.0	5.2	4.6	4.8
32.0 m		3.7	4.5	4.7	4.1	4.3
34.0 m		3.5	4.1	4.3	3.6	3.8
36.0 m		3.3	3.7	3.9	3.2	3.4
38.0 m		3.1	3.4	3.5	2.9	3.0
40.0 m			3.1	3.2	2.6	2.7
42.0 m			2.8	2.9	2.2	2.4
44.0 m			2.4	2.7	1.9	2.1
46.0 m				2.4	1.7	1.8
48.0 m				2.2		1.6
50.0 m				1.9		1.4
52.0 m				1.7		

BOOM ARRANGEMENT CHART

Boom length m (ft)	Boom arrangement
12.2 (40)	Base-Tip
15.2 (50)	Base-A-Tip
18.3 (60)	Base-A-A-Tip, Base-B-Tip
21.3 (70)	Base-A-B-Tip
24.4 (80)	Base-A-A-B-Tip, Base-C-Tip, Base-B-B-Tip
27.4 (90)	Base-A-B-B-Tip, Base-A-C-Tip
30.5 (100)	Base-A-A-B-B-Tip, Base-A-A-C-Tip, Base-B-C-Tip
33.5 (110)	Base-A-B-C-Tip
36.6 (120)	Base-A-A-B-C-Tip, Base-C-C-Tip, Base-B-B-C-Tip
39.6 (130)	Base-A-B-B-C-Tip, Base-A-C-C-Tip
42.7 (140)	Base-A-A-B-B-C-Tip, Base-A-C-C-Tip, Base-B-C-C-Tip
45.7 (150)	Base-A-B-C-C-Tip
48.8 (160)	Base-A-A-B-C-C-Tip, Base-B-B-C-C-Tip, Base-C-C-C-Tip
51.8 (170)	Base-A-B-B-C-C-Tip, Base-C-C-C-Tip
54.9 (180)	Base-A-A-B-B-C-C-Tip, Base-A-A-C-C-C-Tip, Base-B-C-C-C-Tip
57.9 (190)	Base-A-B-C-C-C-Tip
61.0 (200)	Base-A-A-B-C-C-C-Tip

Base = 0.0 m (00'), Tip = 0.0 m (00')
 Inserts: A = 3.05 m (10'), B = 6.1 m (20'), C = 12.2 m (40')

JIB ARRANGEMENT CHART

Jib length m (ft)	Jib arrangement
0.0 (30)	Base-Tip
12.2 (40)	Base-A-Tip
15.2 (50)	Base-B-Tip
18.3 (60)	Base-A-B-Tip

Base = 0.0 m (00'), Tip = 0.0 m (00')
 Inserts: A = 3.05 m (10'), B = 6.1 m (20')

SPECIFICATIONS OF PARTS AND ATTACHMENTS

Base Machine + Boom Base + Crawlers

Weight: 45,250 kg
 Dimensions: 3,450 mm height x 3,610 mm width x 12,170 mm length

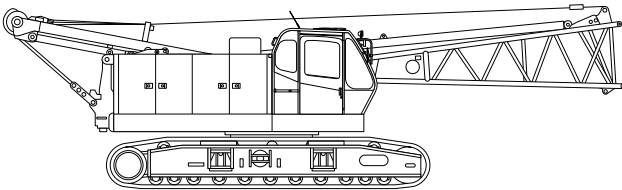

Base Machine + Crawlers

Weight: 43,900 kg
 Dimensions: 3,450 mm height x 3,610 mm width x 8,410 mm length

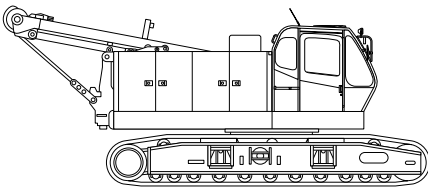

Upper Boom

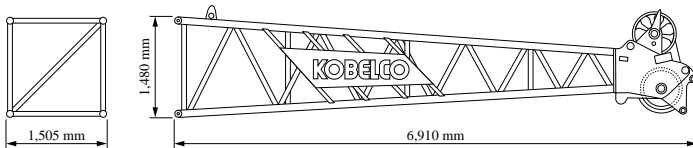

Lower Boom

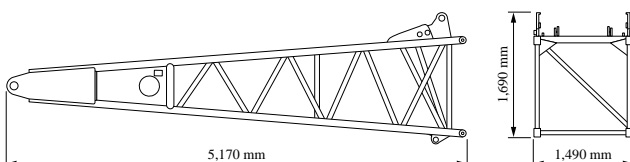

Counterweight

No.1 Counterweight

Weight: 12,070 kg

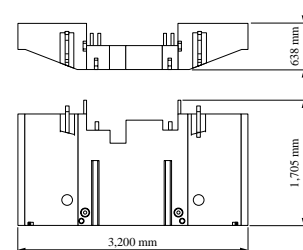

No.2 Counterweight

Weight: 7,373 kg

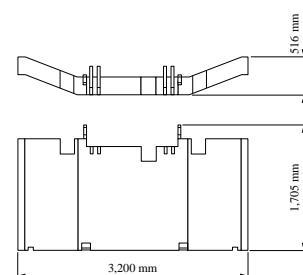

No.3 Counterweight

Weight: 9,347 kg

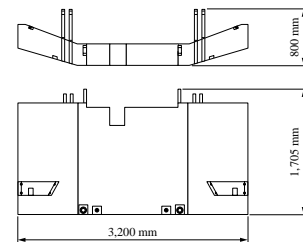

Carbody Counterweight

Weight: 3,340 kg (1 pc)

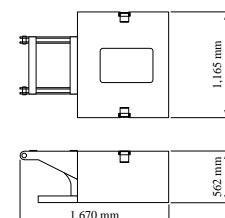

SPECIFICATIONS OF PARTS AND ATTACHMENTS

OTHER ATTACHMENT

Attachment	Weight	Dimensions (L x W x H)
10 ft Insert Boom	310 kg	1,290 mm x 1,490 mm x 3,165 mm
20 ft Insert Boom	520 kg	1,290 mm x 1,490 mm x 6,210 mm
40 ft Insert Boom	960 kg	1,290 mm x 1,490 mm x 12,305 mm
Jib Tip	280 kg	790 mm x 790 mm x 4,960 mm
Jib Base	200 kg	790 mm x 790 mm x 4,810 mm
10 ft Insert Jib	100 kg	790 mm x 790 mm x 3,120 mm
20 ft Insert Jib	180 kg	790 mm x 790 mm x 6,160 mm
Jib Strut	250 kg	620 mm x 840 mm x 3,620 mm
Upper Spreader	270 kg	680 mm x 270 mm x 1,580 mm
90 t hook block	1,300 kg	1,890 mm x 700 mm x 530 mm
70 t hook block	900 kg	1,820 mm x 700 mm x 384 mm
35 t hook block	700 kg	1,575 mm x 700 mm x 470 mm
11 t ball block	450 kg	1,200 mm x 380 mm x dia.

Note: Due to our policy of continual product improvements all designs and specifications are subject to change without advance notice.



KOBELCO CRANES CO., LTD.

17-1, Higashigotanda 2-chome, Shinagawa-ku, Tokyo 141-8626 JAPAN

Tel: ++81 (0) 3-5789-2130 Fax: ++81 (0) 3-5789-3372

Bulletin No. CKE900-S401

04031000 Printed in Japan